

## LIQUEFACTION POTENTIAL ANALYSIS IN TRANS – SULAWESI RAILWAY, POLEWALI MANDAR-MAJENE SEGMENT USING CONE PENETRATION TEST METHOD

DZIKRA ZHAFIRA <sup>1</sup>, IMAM ACHMAD SADISUN <sup>2,3</sup>, TAUFIQ WIRA BUANA <sup>4</sup>

1. Program Studi Teknik Geologi, Fakultas Ilmu dan Teknologi Kebumian, Institut Teknologi Bandung (ITB), Jl. Ganesha No.10, Bandung, Jawa Barat, Indonesia.
2. Kelompok Ilmu Geologi Terapan, Fakultas Ilmu dan Teknologi Kebumian, Institut Teknologi Bandung (ITB), Jl. Ganesha No.10, Bandung, Jawa Barat, Indonesia.
3. Pusat Penelitian Mitigasi Bencana, Institut Teknologi Bandung, Indonesia.
4. Pusat Air Tanah dan Geologi Tata Lingkungan (PATGTL), Jl. Diponegoro No.57, Cihaur Geulis, Kec. Cibeunying Kaler, Kota Bandung, Jawa Barat 40122

***Abstract** - Trans-Sulawesi Railway is the first railway in Sulawesi. One of the segments that is passed by this railway is Polewali Mandar-Majene segment, West Sulawesi. The research focused on this segment and mostly contains of Quaternary sediments such as alluvial. Liquefaction may occur because of earthquake that causes loss of strength within soils. Most of the cases, liquefaction occur in Quaternary sediments that are decomposed, loose, and unconsolidated. So, liquefaction analysis is needed on the research area to determine the liquefaction potential that might happen there. Liquefaction potential analysis was carried out using Cone Penetration Test method (CPT). The analysis was carried out by calculating liquefaction safety factor ( $FS_L$ ) and liquefaction potential index (LPI) at 14 CPT sites with varying depth from 3.8 meters – 14 meters. Based on the analysis, the liquefaction safety factor ( $FS_L$ ) value shown that the 14 CPT sites has a potential for liquefaction with  $M_w$  7.5 earthquake because the  $FS_L$  values are less than 1. Based on the calculation of LPI, the research area is in the high – highest category.*

**Keywords:** Cone Penetration Test (CPT), Polewali Mandar, liquefaction, Liquefaction Potential Index (LPI)

**Sari** – Jalur kereta api Trans-Sulawesi merupakan jalur kereta api pertama di Sulawesi. Salah satu ruas daerah yang dilewati oleh jalur kereta ini adalah daerah penelitian yaitu ruas Polewali Mandar-Majene, Sulawesi Barat. Segmen ini menjadi fokus penelitian dan sebagian besar tersusun atas endapan Kuarter berupa aluvial. Fenomena likuefaksi dapat terjadi akibat dipicu oleh gempa bumi dan menyebabkan tanah kehilangan kekuatannya. Likuefaksi seringkali terjadi pada endapan Kuarter yang cenderung bersifat urai, lepas, dan belum terkonsolidasi. Oleh karena itu, diperlukan analisis untuk menentukan adanya potensi likuefaksi di daerah penelitian. Analisis dilakukan dengan metode uji penetrasi konus atau *Cone Penetration Test* (CPT). Penelitian dilakukan dengan melakukan perhitungan nilai faktor keamanan likuefaksi ( $FS_L$ ) dan indeks potensi likuefaksi (LPI) pada 14 titik sondir dengan kedalaman bervariasi dalam rentang 3.8 m – 14 m. Berdasarkan hasil analisis, nilai  $FS_L$  yang didapatkan memperlihatkan bahwa di 14 titik uji sondir berpotensi untuk terjadi likuefaksi pada gempa berkekuatan  $M_w$  7.5 karena memiliki nilai  $FS_L$  kurang dari 1. Berdasarkan hasil perhitungan nilai LPI, daerah penelitian masuk ke dalam kategori tinggi – sangat tinggi.

**Kata kunci:** Cone Penetration Test (CPT), Polewali Mandar, likuefaksi, Liquefaction Potential Index (LPI)

## 1. INTRODUCTION

According to Das (1993), liquefaction is an event of loss of the strength of the soil layer due to vibrations, such as vibrations caused by an earthquake, so that the soil is unable to support the load on it. Liquefaction usually occurs in water-saturated soils and the entire cavity of the soil is filled with water. When a vibration occurs, water exerts a pressure on the soil particles so that it affects the density of the soil, the pore water pressure increases, and the soil has no bearing capacity (**Figure 1**).

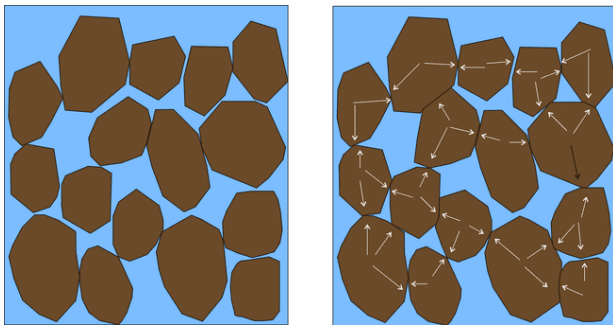

**Figure 1.** Soil grains and contact forces between grains.

The cone penetration test is a field penetration test with tools shaped like a cone (**Figure 2**), to obtain the parameters of the penetration resistance of the soil layers in the field. These parameters are cone tip resistance ( $q_c$ ), friction resistance ( $f_s$ ), friction ratio ( $R_f$ ), and total soil friction ( $T_f$ ), which can be used for the interpretation of soil layers.

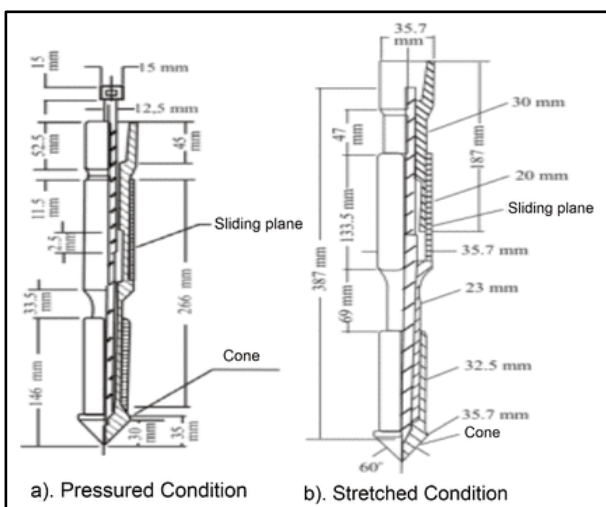

**Figure 2.** Cone penetration tools (SNI 2827:2008).

In general, West Sulawesi is an area that is very prone to tectonic movements. Tectonic movements that occur can cause earthquakes that have the potential to cause liquefaction phenomena. The area of West Sulawesi has a morphology of hills to steep hills, valleys, and coastal plains composed of Pre-Tertiary, Tertiary, and Quaternary sediments. There are 14 sites where the CPT test took place and they were located on the southern part of Polewali Mandar (**Figure 3**).

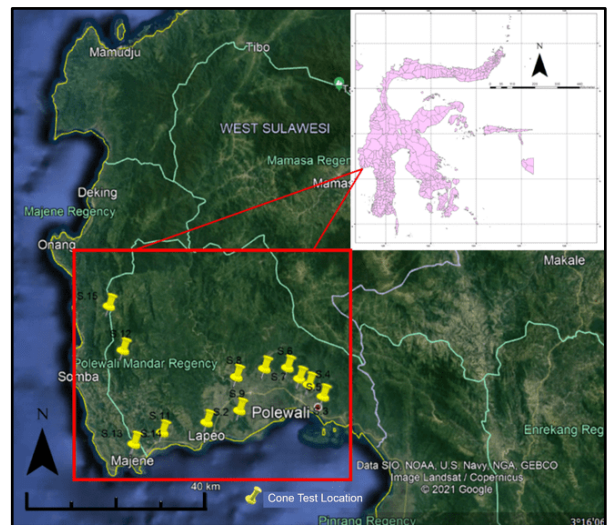

**Figure 3.** Research area (Google Earth, downloaded on June 5<sup>th</sup>, 2021).

## 2. DATA AND METHODOLOGY

Data used in this research is secondary data. The data consists of 2: CPT data, and PGA data. The CPT data consists of cone tip resistance ( $q_c$ ), friction resistance ( $f_s$ ), friction ratio ( $R_f$ ), total soil friction ( $T_f$ ) (**Figure 4**), and physical properties of the soil. The PGA data was generated from PGA map on bedrock for probability exceeded 10% in 50 years (**Figure 5**).

$q_c$  and  $f_s$  value will be used for the calculation of CRR (Cyclic Resistance Ratio) and CSR (Cyclic Stress Ratio). CRR is a value that represents the resistance capacity of the soil to liquefaction. CSR symbolizes the seismic magnitude of a soil layer (Youd et al., 2001). The  $FS_L$  value will be obtained from the ratio of CRR and CSR (Kramer, 2008) (**Figure 6**).

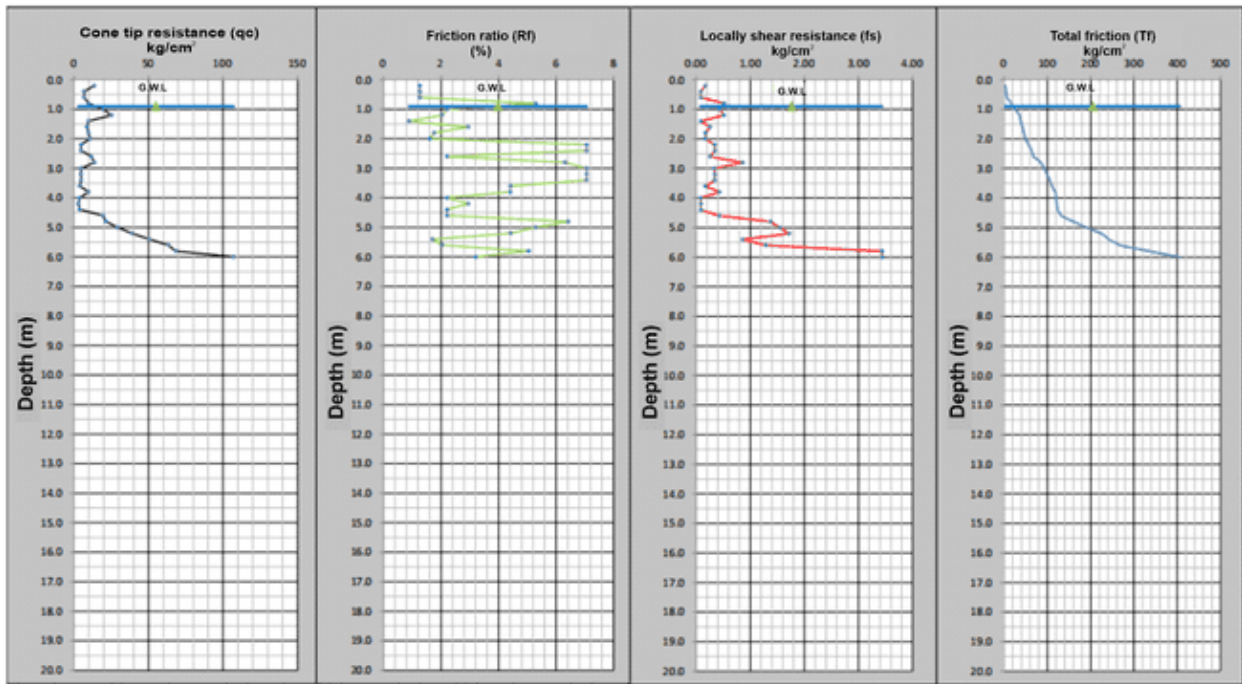

Figure 4. CPT data from site S.1.

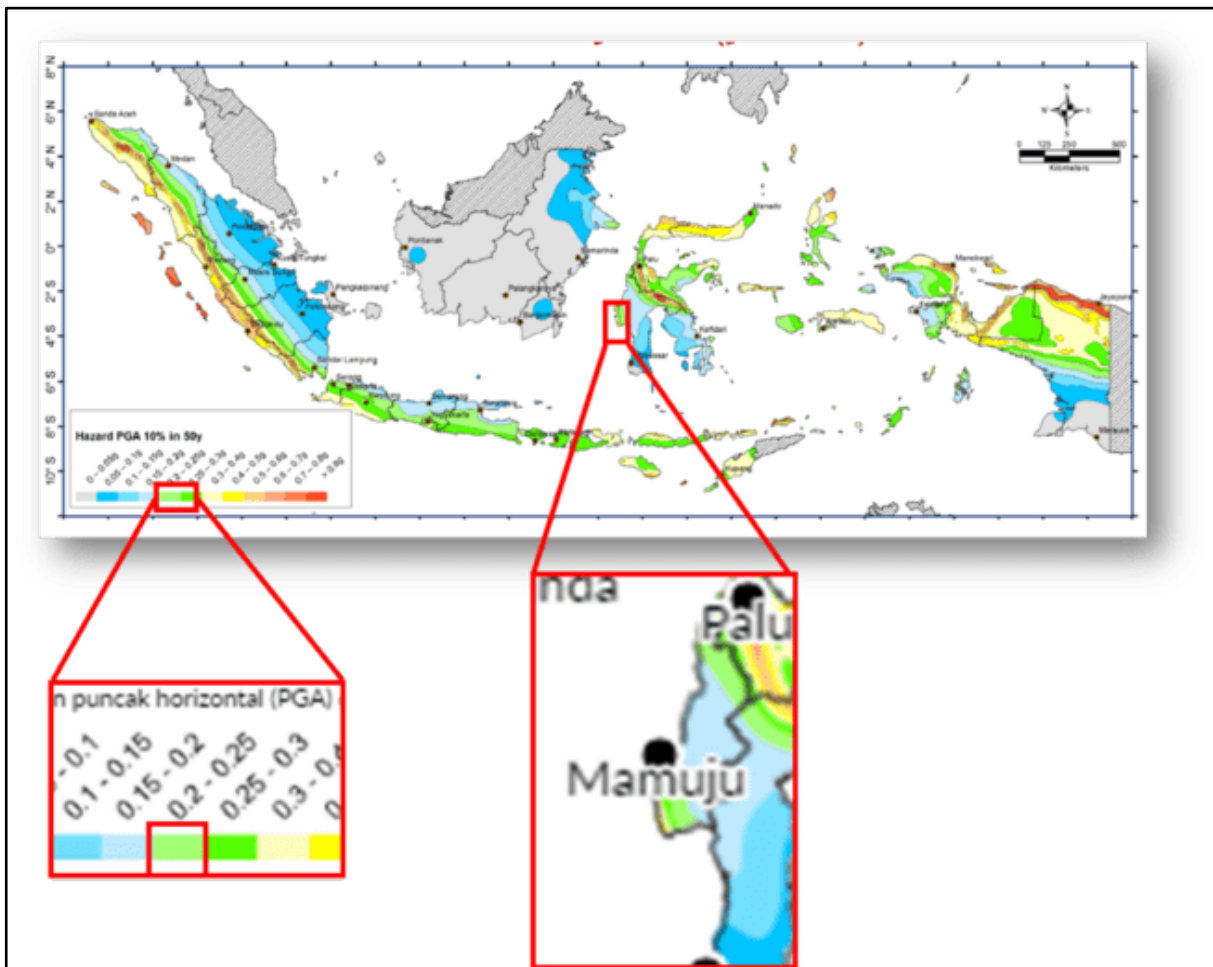

Figure 5. PGA map on bedrock for probability exceeded 10% in 50 years ([lini.binamarga.pu.go.id](http://lini.binamarga.pu.go.id), downloaded on August 6<sup>th</sup>, 2021).

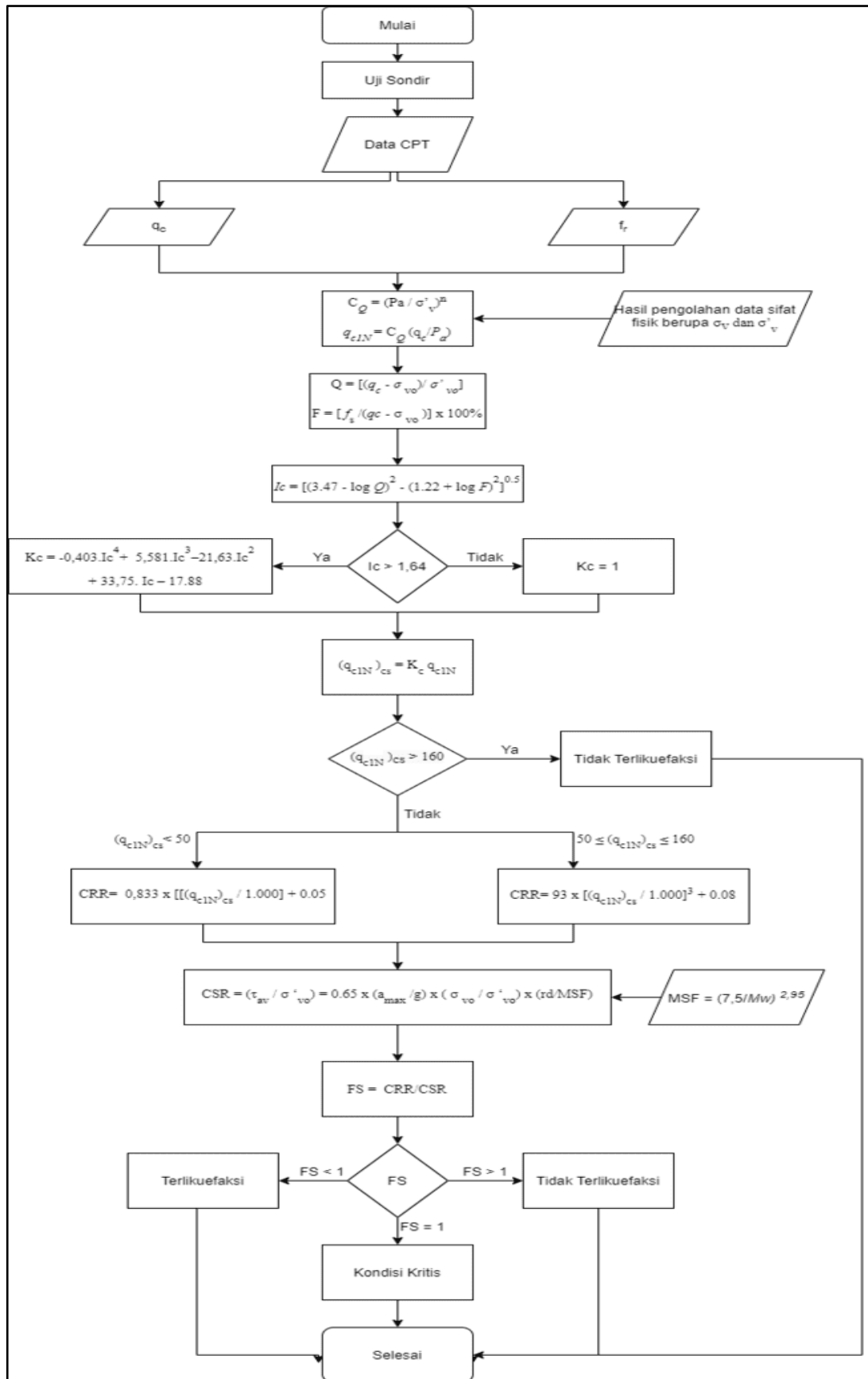

Figure 6. Flowchart for FS<sub>L</sub> calculation.

In this research also carried out the calculation of Liquefaction Potential Index (LPI) based on Iwasaki et al. (1981).

$$LPI = \int_0^{20m} F(z) \cdot w(z) dz$$

with:

$$F(z) = 1 - FSL \text{ for } FSL < 1.$$

$$F(z) = 0 \text{ for } FSL \geq 1.$$

$$w(z) = 10 - 0,5z \text{ for } z < 20 \text{ m.}$$

$$w(z) = 0 \text{ for } z \geq 20 \text{ m.}$$

Liquefaction potential index based on the LPI value are divided into 4 categories (**Table 1**).

**Table 1.** Liquefaction potential category based on LPI (Iwasaki et al., 1981).

LPI Value	Liquefaction Potential Category
LPI = 0	Very low
0 < LPI ≤ 5	Low
5 < LPI ≤ 15	High
LPI > 15	Very High

### 3. RESULTS

The research area consists of 6 units of lithology: Alluvium, Napal Pambauang, Intrusion Rocks, Walimbong Volcanic Rocks, Mapi Formation, and Mandar Formation (**Figure 7**). The red points are where the cone penetration test locations, and mostly they are on the Alluvium unit.

At the research site, there are 14 CPT test sites. The calculations based on the flowchart above performed to determine the value of the safety factor. In this calculation, an earthquake scenario with a magnitude of 7.5 Mw. It is assumed that the PGA value at the research site has the same value at every location. The PGA value is 0.25.

In conducting the analysis of liquefaction triggers, the value of the liquefaction safety factor (FSL) is needed which is obtained from the results of the distribution between the CRR values and the CSR values. The following calculation example is the calculation of the CPT points at depth of 20 cm from the surface.

Known value:

- CPT sites : S.1
- Layer Number : 1
- Layer Depth : 20 cm
- GWL (Ground Water Level) : - 90 cm
- Soil volume weight ( $\gamma$ ) : 0.00158 kg/cm<sup>3</sup>
- $q_c$  : 14 kg/cm<sup>2</sup>
- $f_s$  : 0.16 kg/cm<sup>2</sup>
- Gravitational acceleration ( $g$ ) : 9.80 m/s<sup>2</sup>
- $n$  : 1
- $a_{max}$  : 0.25 g

#### a. Total stress ( $\sigma_{vo}$ )

$$\begin{aligned} \sigma_{vo} &= h \times \gamma \\ &= (20 \text{ cm}) (0.00158 \text{ kg/cm}^3) \\ &= 0.0316 \text{ kg/cm}^2 \end{aligned}$$

#### b. Effective stress ( $\sigma'_{vo}$ )

$$\begin{aligned} \sigma'_{vo} &= \sigma_{vo} - u \\ &= (h \times \gamma) - (hw \times \gamma_w) \\ &= (20 \times 0.00158) - (0 \times 0.000981) \\ &= 0.0316 \text{ kg/cm}^2 \end{aligned}$$

#### c. Cone penetration resistance normalization

$$\begin{aligned} q_{c1N} &= C_Q (q_c / P_a) \\ C_Q &= (P_a / \sigma'_{vo})^n \\ &= 5.718 \\ q_{c1N} &= C_Q (q_c / P_a) \\ &= 77.479 \end{aligned}$$

#### d. Soil index behavior

$$I_c = [(3.47 - \log Q)^2 - (1.22 + \log F)^2]^{0.5}$$

$$\begin{aligned} Q &= [(q_c - \sigma_{vo}) / P_a] [(P_a / \sigma'_{vo})^n] \\ &= [(q_c - \sigma_{vo}) / P_a] [(P_a / \sigma'_{vo})] \\ &= [(q_c - \sigma_{vo}) / \sigma'_{vo}] \\ &= [(14 - 0.0316) / 0.0316] = 442.037 \end{aligned}$$

$$\begin{aligned} F &= [f_s / (q_c - \sigma_{vo})] \times 100\% \\ &= [0,16 / (14 - 0.0316)] \times 100\% \\ &= 0.011 \end{aligned}$$

$$\begin{aligned} I_c &= [(3.47 - \log 442,037)^2 - (1.22 + \log 0,011)^2]^{0.5} \\ &= 1.095 \end{aligned}$$

for  $I_c \leq 1.64$ ,  $K_c = 1.0$



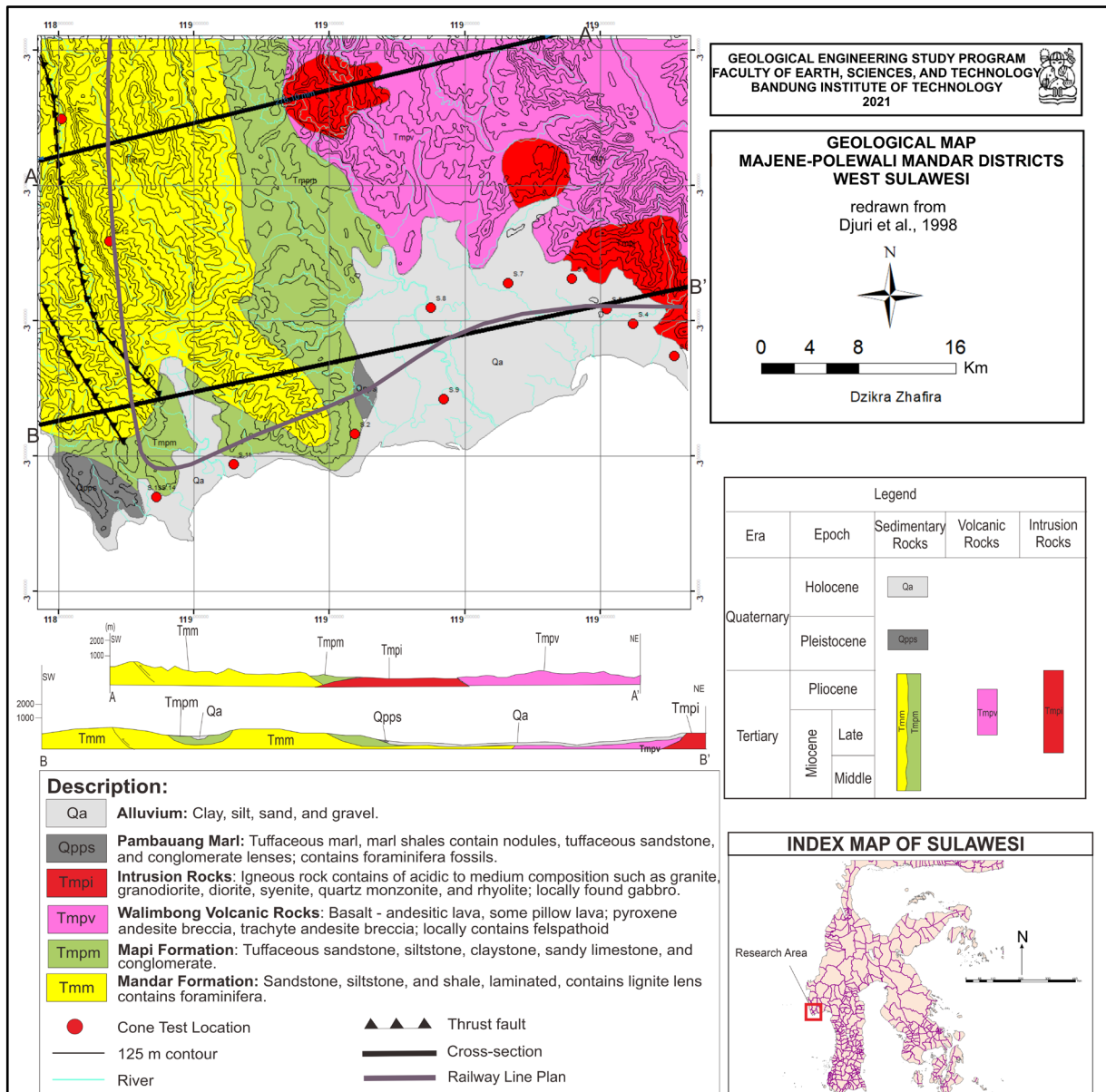

Figure 7. Geological map of the research area (redrawn from Djuri et al., 1998).

**e. Corrected cone resistance value**

$$\begin{aligned} (q_{c1N})_{cs} &= Kc q_{c1N} \\ &= 1 \times 77,479 \\ &= 77,479 \end{aligned}$$

**f.  $CRR_{7,5}$  value**

$$\begin{aligned} \text{If } 50 \leq (q_{c1N})_{cs} < 160, CRR_{7,5} &= 93 \times \left[ \frac{(q_{c1N})_{cs}}{1000} \right]^3 + 0,08 \\ CRR_{7,5} &= 93 \times \left[ \frac{77,479}{1000} \right]^3 + 0,08 \\ &= 0,123 \end{aligned}$$

**g. CSR value**

$$\begin{aligned} CSR &= 0.65 \times \frac{a_{max}}{g} \times \frac{\sigma_{vo}}{\sigma'_{vo}} \times r_d \\ r_d &= \frac{1 - 0.4113z^{0.5} + 0.04052z + 0.001753z^{1.5}}{1 - 0.4117z^{0.5} + 0.05729z - 0.006205z^{1.5} + 0.00121z^2} \\ r_d &= \frac{1 - 0.4113 \times 0.2^{0.5} + 0.04052 \times 0.2 + 0.001753 \times 0.2^{1.5}}{1 - 0.4117 \times 0.2^{0.5} + (0.05729 \times 0.2) - (0.006205 \times 0.2^{1.5}) + 0.00121 \times 0.2^2} \\ r_d &= 0.996 \\ CSR &= 0.65 \times \frac{0.25g}{g} \times \frac{0.0316}{0.0316} \times 0.996 \\ &= 0.149 \end{aligned}$$

**h. Liquefaction safety factor**

$$FS_L = \frac{CRR_{7,5}}{CSR} = \frac{0.123}{0.149} = 0.827$$

**i. Liquefaction potential index**

$$F(z) = 1 - FS_L = 1 - 0,827 = 0.173$$

$$w(z) = 10 - 0,5z = 10 - 0,5(0,2) = 9.9$$

$$\Delta LPI = F(z).w(z).z = 0.173 \cdot 9.9 \cdot 0.2 = 0.34$$

Based on the calculation above, the FSL value is less than 1. We can conclude that layer number 1 is liquefiable. The calculation done on each layer at every CPT sites. We also calculate the ΔLPI value at layer 1 and we got 0.34. The calculation done on each layer at every CPT sites, and we sum up the ΔLPI value in every layer until we get the total LPI value.

**4. DISCUSSION**

There are 14 CPT sites that was spread on the southern part of Polewali Mandar. The sites mostly composed of the Alluvium Unit, Mapi Formation, and Mandar Formation.

From the 14 CPT sites, the analysis that was carried out were liquefaction safety factor (FSL) calculation and Liquefaction Potential Index calculation. Based on the calculation at the 14 CPT sites, all the points have liquefaction potential. The layer that is liquefiable has FSL value less than 1 (**Figure 8**) because most of the layers have CRR values that are smaller than the CSR values (**Figure 9**). The soil on the research area is quite soft and it is shown on the small values of the cone tip resistance. It is also resulting on the small CRR values. Besides, all the sites have LPI values more than 5.

This is the summary of LPI values and depth of liquefiable layers at the 14 CPT sites. based on the LPI values, the 14 CPT sites all have potential for liquefaction in high - very high category (**Table 2**) and the depth of liquefiable layers varied from 3.8 m until 14 m (**Table 3**).

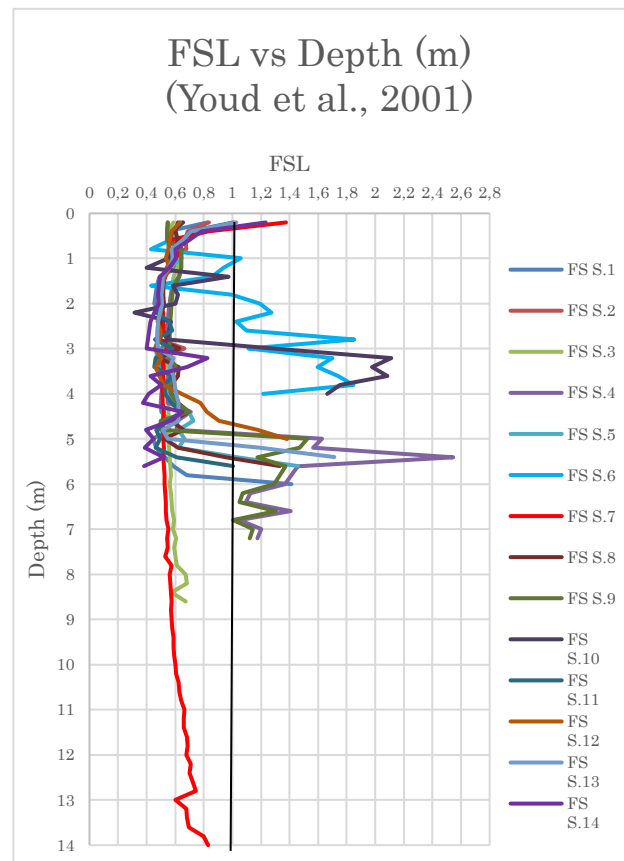

**Figure 8.** Graphic of the FSL values to depth.

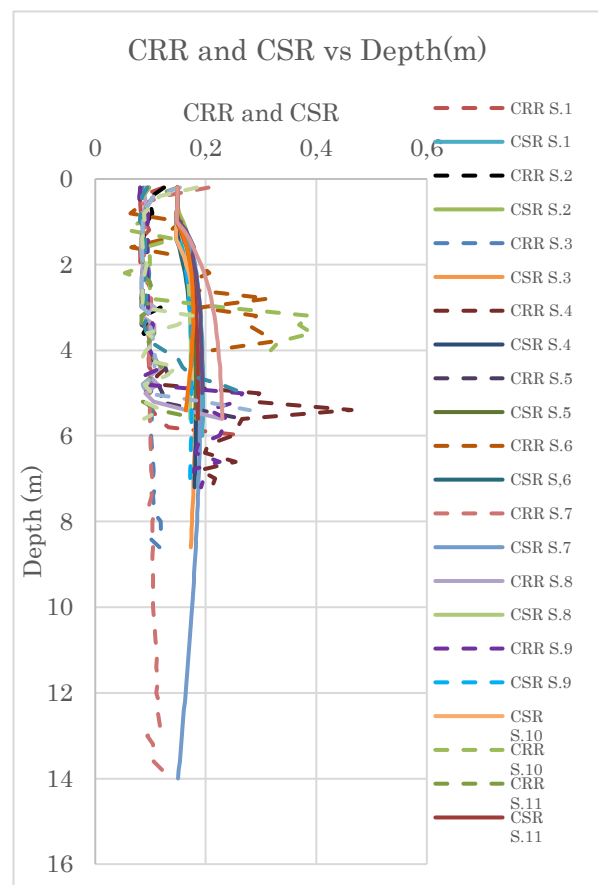

**Figure 9.** Graphic of the CRR and CSR values to depth.

**Table 2.** LPI values at 4 CPT sites.

Code	LPI	Description
S.1	22,862	Very High
S.2	14,162	High
S.3	28,452	Very High
S.4	17,728	Very High
S.5	19,820	Very High
S.6	5,097	High
S.7	37,883	Very High
S.8	19,447	Very High
S.9	19,957	Very High
S.10	10,211	High
S.11	20,302	Very High
S.12	17,755	Very High
S.13	18,383	Very High
S.14	22,101	Very High

**Table 3.** Depth of liquefiable layers at 14 CPT sites.

Code	Total Depth of Layers (m)	Depth of Liquefiable Layers (m)
S.1	6	0 - 5,8
S.2	3,8	0 - 3,8
S.3	8,6	0 - 8,6
S.4	7,2	0 - 4,8
S.5	5,6	0 - 5,2
S.6	4	0 - 1,8
S.7	14	0 - 14
S.8	5,6	0 - 5,4
S.9	7,2	0 - 4,8
S.10	4	0 - 2,8
S.11	5,6	0,4 - 5,4
S.12	5	0 - 4,6
S.13	5,4	0,4 - 5
S.14	5,6	0,4 - 5,6

From the table above, we can conclude that all the CPT points at the research area are liquefiable in varying depths of layers and varying category of liquefaction potential index.

## 5. CONCLUSION

Based on the analysis, the liquefaction safety factor (FSL) values obtained shown that the 14 CPT sites has a potential for liquefaction with Mw 7.5 earthquake because the FSL values are less than 1. Based on the calculation of liquefaction potential index (LPI), the research area is in the high – highest category.

## ACKNOWLEDGMENT

We would like to thank Center of Groundwater and Environmental Geology for providing all the datas that has been used in this paper.

## REFERENCES

- Djuri, Sudjatmiko, S. Bachri, Sukido. 1998: *Peta Geologi Lembar Majene dan Bagian Barat Lembar Palopo, Sulawesi Skala 1:250.000 Edisi Kedua*. Bandung: Pusat Penelitian dan Pengembangan Geologi.
- Iwasaki, T., Tokida, K., and Tatsuoka, F. 1981: Soil liquefaction potential evaluation with use of the simplified procedure, *International Conference on Recent Advances in Geotechnical Earthquake Engineering and Soil Dynamics, St. Louis*, 209–214.
- Kramer, S. L. 2008: *Evaluation of Liquefaction Hazards in Washington State*. Seattle: Washington State Transportation Center (TRAC).
- Youd, T.L., Idriss, I.M., Andrus, R.D., Arango, I., Castro, G., Christian, J.T., Dobry, R., Finn, W.D.L., Harder Jr., L.F., Hynes, M.E., Ishihara, K., Koester, J.P., Liao, S.S.C., Marcuson III, W.F., Martin, G.R., Mitchell, J.K., Morwaki, Y., Power, M.S., Robertson, P.K., Seed, R.B., dan Stokoe II, K.H. 2001: Liquefaction Resistance of Soils: Summary Report From The 1996 NCEER and 1998 NCEER/NSF Workshops on Evaluation of Liquefaction Resistance of Soils, *Journal of Geotechnical and Geoenvironmental Engineering*, Vol. 127, 817-833.

## Sources from web site

- Google Earth (2020), [www.earth.google.com](http://www.earth.google.com), accessed June 5<sup>th</sup> 2021.
- Lini Binamarga Pekerjaan Umum (2021), [lini.binamarga.pu.go.id](http://lini.binamarga.pu.go.id), accessed August 6<sup>th</sup> 2021.